

Corner Drum Depalletiser

DTP05



Technical specification:

- safe working load (SWL) 350kg;
- unit weight 83kg;
- lift height 370mm;
- width 1240mm;
- height 1400mm;
- length 850mm;
- adjustable stainless steel drum catch for use 50- to 220-litre drums;
- 160mm front wheels;
- 100mm rear castor wheels with parking brakes;
- mild steel shot blast, zinc enriched primer and powder coat RAL5010 applied;
- manual hydraulic lift;
- for use on smooth, level floors;
- complies with EC Machinery Directive 2006/42/EC;
- CE marked;
- shipping dimensions- assembled 1200mm X 1000mm X 1520mm (width X depth X height).

Unit options:

- ATEX compliant model available;
- 304-grade stainless steel available.

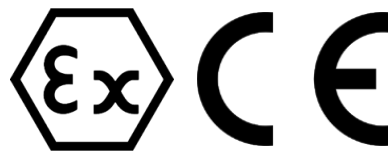

The DTP05 is a corner depalletiser with manually operated hydraulic lift which is designed to lift and manoeuvre various drum types. The Corner Drum Depalletiser is specifically designed for lifting and moving drums and barrels from pallets in areas where space is limited. This drum lifter can collect drums placed on each of the four corners of a pallet, it requires access to all sides of the pallet; a pallet truck may be needed to move the pallet for access to each corner. If you require an ATEX certified unit for a hazardous area please consider our ATEX-rated model, the DTP05-Ex.



Bespoke
Handling
Equipment

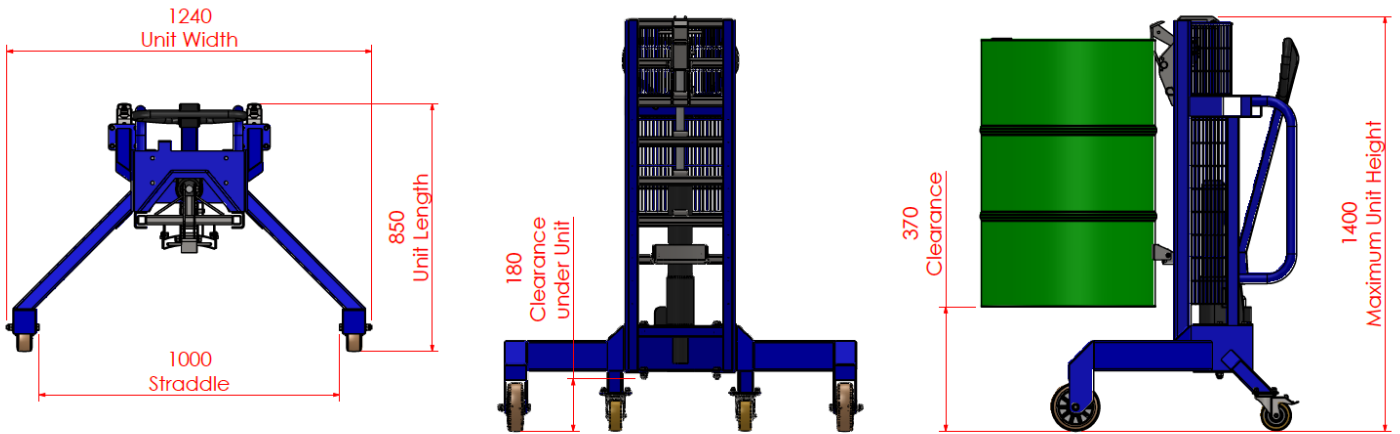

Below is a plan view showing a 200-litre drum being removed from a 1200mm x 1200mm pallet using the DTP05 Corner Depalletiser:

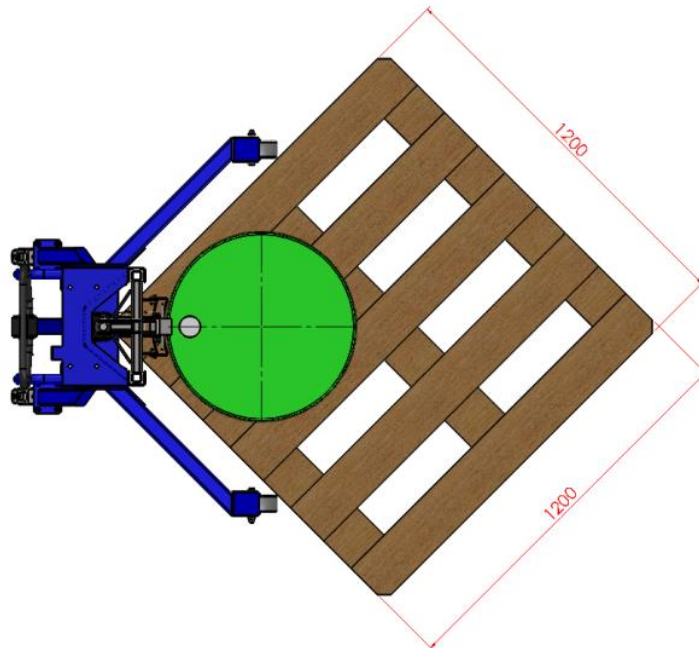

UK
Manufacture

BESPOKE HANDLING EQUIPMENT LTD (T.A. STS)
Praze Rd Leedstown, Hayle, Cornwall, TR27 6DS
Tel: 01736 851050 Fax: 01736 851023
Website: www.sts-trolleys.co.uk
Email: sales@sts-trolleys.co.uk



YouTube